

Mahindra

IMPLEMENTS



Mahindra
TOUGHEST
TRACTORS
ON EARTH

Aug 2018



PUSH MORE.
PULL MORE.
LIFT MORE.



3 Pt Standard Duty (Sd) Rotary Cutter

SMART CHOICE BENEFITS

- Quick Hitch compatible
- 40 HP gear box with 5 year warranty
- Laminated tail wheel
- Your choice of shear bolt or slip clutch PTO
- Front and Rear chain guard optional
- 11GA steel deck, single piece
- Fully welded rotary cutter top not skip welded
- Welded on, not bolted lower link lift points
- 7" Side bands
- Replaceable skid shoes
- Stump jumper standard

Specification	40"	48" (4')	60" (5')	72" (6')
Minimum HP Requirements	19-22 HP	22-25 HP	25-33 HP	33-40 HP
Hitch Type	CAT I	CAT I	CAT I	CAT I
PTO	Series 4	Series 4	Series 4	Series 4
Deck Thickness	11 GA Steel	11 GA Steel	11 GA Steel	11 GA Steel
Side Bands	HD 7" Channel	HD 7" Channel	HD 7" Channel	HD 7" Channel
Gearbox	40 HP	40 HP	40 HP	40 HP
Stump Jumper	Formed Round Pan	Formed Round Pan	Formed Round Pan	Formed Round Pan

3 Pt Medium Duty (Md) Rotary Cutter

SMART CHOICE BENEFITS

- Quick Hitch compatible
- 90 HP gear box with 5 year warranty
- Laminated tail wheel
- Your choice of shear bolt or slip clutch PTO
- Front and Rear chain guard optional
- 11GA steel deck, single piece
- 3" cutting capacity
- Welded on, not bolted lower link lift points
- 7" Side bands
- Replaceable skid shoes
- Stump jumper standard

Specification	60" (5')	72" (6')
Minimum HP Requirements	35-42 HP	40-50 HP
Hitch Type	CAT I	CAT I
PTO	Series 4	Series 4
Deck Thickness	11 GA Steel	11 GA Steel
Side Bands	HD 7" Channel	HD 7" Channel
Gearbox	90 HP	90 HP
Stump Jumper	5/8" Solid Stump Jumper	5/8" Solid Stump Jumper



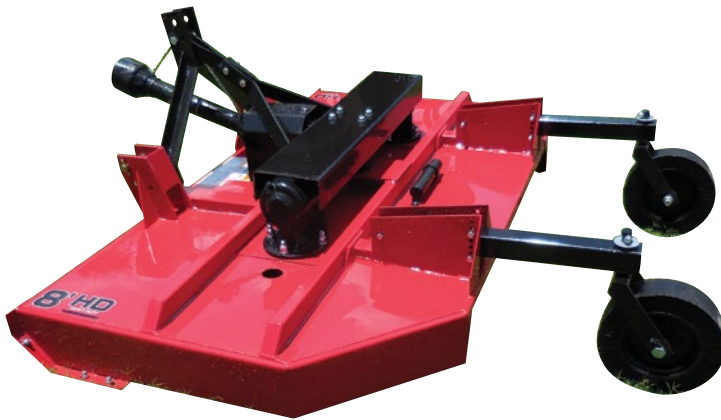

Heavy Duty Cutters - Lift Type

SMART CHOICE BENEFITS

- Slip Clutch PTO
- 3pt mount with reliable breakaway
- 90 HP Gearbox
- 5', 6', 7', 8' and 10' widths available
- Solid Stump Jumper
- Fully welded deck
- Laminated dual tail wheels with hub bearings
- Cuts 3" diameter material at ground level
- Replaceable skid shoes
- Rear and front chain guards
- CAT II quick hitch compatible (operator must verify PTO shaft length and clearance from quick hitch)



Heavy Duty Cutters - Pull Type

SMART CHOICE BENEFITS

- Slip Clutch PTO
- Easy connect pull-type mount
- 90 HP Gearbox
- Solid Stump Jumper
- Fully welded deck
- Laminated dual tail wheels with hub bearings
- Cuts 3" diameter material at ground level
- 5', 6', 7', 8' and 10' widths
- Replaceable skid shoes
- Options: Rear & Front chain guards



Flex-Wing Cutters

SMART CHOICE BENEFITS

- 15' Flex Wing Rotary Cutter
- Dual purpose
- Heavy brush cutting
- Smooth pasture cutting
- Rugged, durable construction
- Row/Width Adjustable
- New for 2015 - Airline tire option
- Recommended minimum 50 PTO HP
- 190 HP center/wing gear box with 5 year warranty
- 235 HP splitter gear box
- Front and Rear chain guards standard
- 7GA (3/16) steel deck, single piece
- 4" cutting capacity
- 2" to 10" cutting height
- 1/4" Thick Channel Side bands
- 9.5" deep deck
- Replaceable skid shoes
- Stump jumper standard, 3/4" thick disc
- 540 standard - 1000 RPM Optional
- Wing flex 900 up - 220 down
- 15,342 FPM blade p speed
- 6.5" blade overlap
- Swivel Pivot Hitch





Standard - Heavy Duty Box Scrapers

SMART CHOICE BENEFITS

- Quick hitch ready for a speedy clip on & off
- Slots in which the shanks are inserted are reinforced for a longer life span
- Wide cutting edge in front and back not only protects the scraper but assists in successful results
- Moves larger quantities of loose material to minimize work time

Tillers

SMART CHOICE BENEFITS

- Quick hitch ready for a speedy clip on & off
- All gear drive for a powerful and dependable performance
- Major components are well sealed to prolong life span
- Part are easily replaceable when repairs are required rendering this unit very user friendly

	STANDARD	HEAVY DUTY
Weight	4': 770 lbs 5': 820 lbs 6': 830 lbs	5': 900 lbs 6': 1000 lbs 7': 1150 lbs
For Tractors	4': Up to 55HP 5': Up to 55HP 6': Up to 55HP	5': Up to 55HP 6': Up to 55HP 7': up to 55HP
Hitch	Category 1, quick hitch ready with clevis pins for fast hook up.	
Slots	Reinforced slots, prolongs use without splaying.	
Shanks	Heavy duty, replaceable and adjustable.	
Tips	Made of hardened steel and replaceable.	
End plates	Made of 1/4" steel.	Made of 3/8" steel.
Cutting edges	Protects both rear and front of scraper, 3/8" thick x 6" wide. Curved, reversible & replaceable.	
Warranty	Residential, semi-commercial, regular commercial use: 1 year	

Weight	4' : 500 lbs 5' : 670 lbs 6' : 750 lbs approx.
For Tractors	4' : 20—50HP 5' : 20—50HP 6' : 20—50HP
Hitch	Category 1, quick hitch ready double strap hook up for sturdiness and durability.
Hook up	Double strap for sturdiness and durability.
Guard	Bearings covered by a sealed guard to avoid damage from wrapping.
Tines	High resistance steel tines
Parking stand	For storage and to assist in installation.
Skid shoes	Adjustable
Panel	Wider to cover tracks
Gears	Heavy duty all gear drive
Protection	Slip clutch protection system
Offset	May be offset to right
Depth	Tilling depth up to 5 inches
Warranty	Residential, semi-commercial, regular commercial use: 1 year



3 Point Hitch Finish Mowers

SMART CHOICE BENEFITS

- Quick hitch ready for a speedy clip on & off
- Numerous adjustable parts to accomplish a wide variety of mowing needs
- Low maintenance machine and the little maintenance required is easily accessible

Weight	4': 400 lbs 5': 509 lbs 6': 549 lbs approx. 7': 803 lbs
For Tractors	14 - 40 HP recommended for 48" 23 - 40 HP recommended for 60" 32 - 40 HP recommended for 72" 35 - 50 HP recommended for 84"
Hitch	Category 1, with clevis pins for fast hook up
Floating hitch	Adjustable front & rear to hug uneven terrain
Gear box	Heavy duty with a 5yr limited warranty
Wheel adjustment	To adjust cutting height. Large pivoting wheels for better flotation.
Discharge	Rear discharge
Anti-scalp	Anti-scalp wheels to avoid damaging lawns
Spindles	Greasable with check valves
Protection	Shear bolt protection system
Height adjustment	To match tractor's PTO
Offset	Horizontal offset adjustable
Blades	3 high quality 21" blades mounted on spindles
Belt	Self adjusting belt tensioner
Warranty	Residential, semi-commercial, regular commercial use: 1 year



3 Point Quick Hitch

SMART CHOICE BENEFITS

- Heavy duty construction for years of reliable service
- Adapter kit for clevis type connections

Weight	84 lbs approx.
For Tractors	With Category 1 & Cat II hitch
Hook	Adjustable top hook
Hitch	Auto lock
Construction	Heavy duty construction
Release	Quick release levers
Warranty	Residential, semi-commercial, regular commercial use: 1 year





Economy Rear Blades

SMART CHOICE BENEFITS

- Quick Hitch compatible, Category I
- Can Pivot 150 or 300 forward or backward
- Widths of 4', 5', 6' and 7'
- Slide adjustable for tight spots
- 5 forward/5 reverse angle positions
- 1/2" X 6" reversible cutting edge
- Quick hitch compatible

Description	2WD - HP	4WD - HP	Weight
4' Economy Blade	17-24	14-20	158
5' Economy Blade	19-25	16-20	179
6' Economy Blade	21-28	18-23	202
7' Economy Blade	23-32	20-26	223



Land Levelers

SMART CHOICE BENEFITS

- 3/8" X 6" reversible cutting edge
- Quick Hitch compatible, Category I
- Widths of 5', 6' and 7'
- Overall length 65"
- Side Panel Height 14", Side Panel thickness 3/16"
- Replaceable skid shoes
- Heat treated reversible cutting edges
- 60" 25-50 HP
- 72" 25-50 HP
- 84" 30-60 HP

Standard Duty Rear Blade, Tilt & Slider

SMART CHOICE BENEFITS

- Key Selling Features:
- 5 forward/5 reverse angle positions
- Pin-tilt adjustments for ditching
- Moldboard height 13 1/2"
- 1/2" x 6" reversible cutting edge
- Slider Blade A-Frame Standard
- Quick hitch compatible

Weight	5': 550 lbs 6': 570 lbs 7': 640 lbs approx.
For Tractors	5': Up to 40 HP 6': Up to 40 HP 7': Up to 40 HP
Hitch	Category 1, quick hitch ready with clevis pins for fast hook up.
Moldboard	Made of 1/4" steel, 13- 1/2" high
Angling	7 forward and reverse positions
Cutting edge	Heavy duty reversible and replaceable edge 3/8" x 6"
Lock pins	Slots reinforced with steel sleeves.
Parking stand	For storage, also assists in installation.
Offset	Manual offset feature of 12" capability left or right sides
Option	Coming at a later date: Rake to install on same hitch.
Warranty	Residential, semi-commercial, regular commercial use: 1 year



Medium Duty Blades

SMART CHOICE BENEFITS

- 5 forward/5 reverse angle positions
- Pin-tilt adjustment for ditching
- Moldboard height 15 1/2" reinforced
- 1/2" X 6" reversible cutting edge
- Quick hitch compatible

Heavy Duty (HD) Blades

SMART CHOICE BENEFITS

- Key Selling Features:
- 5 forward/5 reverse angle positions
- Pin-tilt adjustment for ditching
- Moldboard height 17 1/2" reinforced
- Quick hitch compatible

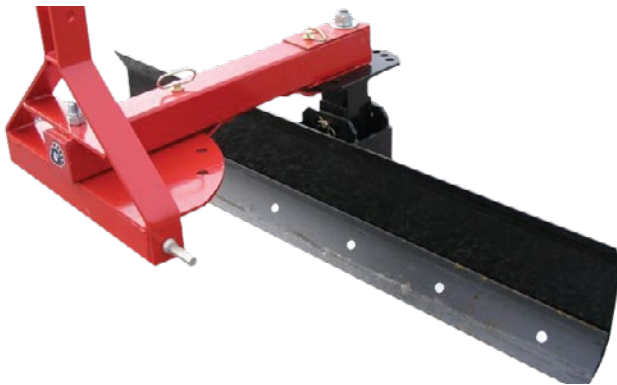

Medium Duty Offset

SMART CHOICE BENEFITS

- 5 position offset
- 5 forward/5 reverse angle positions
- Pan-tilt adjustment for ditching
- Moldboard height 15 1/2"
- 1/2" X 6" reversible cutting edge
- Quick hitch compatible

Weight	6': 632 lbs 7': 667 lbs 8': 702 lbs approx.
For Tractors	6': 4WD up to 65HP, 6': 2WD up to 80HP 7': 4WD up to 65HP, 7': 2WD up to 80 HP 8': 4WD up to 65HP, 8': 2WD up to 80HP
Hitch	Category 1 or 2, quick hitch ready with double strap hook up for sturdiness and durability.
Moldboard	Made of 5/16" steel, 13-1/2" high
Angling	Manual angling 9 forward and reverse positions. Optional hydraulic angling
Cutting edge	Heavy duty reversible and replaceable edge 1/2" x 6"
Parking stand	For storage, also assists in installation.
Offset	Manual offset feature of 30" capability left or right sides
Options	Coming at a later date: Hydraulic angling, hydraulic offset, hydraulic tilt,
Warranty	Residential, semi-commercial, regular commercial use: 1 year

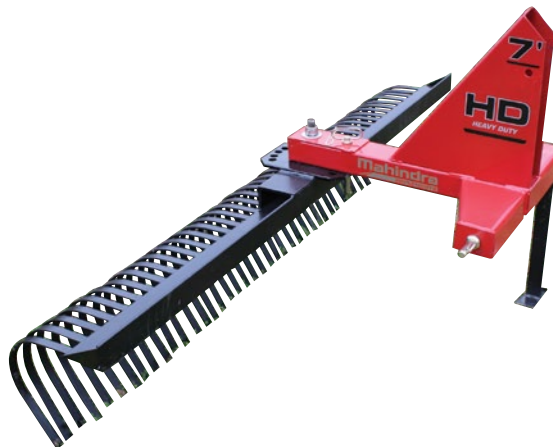

Standard Duty Landscape Rakes

SMART CHOICE BENEFITS

- 4 angle positions both forward and revers
- 4/16"X1 tempered nes
- SD Main frame 4"X4" - 5/15"
- Various angle positions
- Optional Gauge wheel kit

MODEL #	DESCRIPTION	WEIGHT (LBS.)
KLRSD4	SD Landscape Rake 4'	461
KLRSD5	SD Landscape Rake 5'	523
KLRSD6	SD Landscape Rake 6'	588
KLRSD7	SD Landscape Rake 7'	650
KLRSD8	SD Landscape Rake 8'	726

Heavy Duty Landscape Rakes

SMART CHOICE BENEFITS

- Various angle positions
- 4/16"X1 tempered nes
- HD Main frame 5"X3" - 3/8"
- Various angle positions
- Optional gauge wheels for depth control

MODEL #	DESCRIPTION	WEIGHT (LBS.)
KLRHD4	HD Landscape Rake 4'	461
KLRHD5	HD Landscape Rake 5'	523
KLRHD6	HD Landscape Rake 6'	588
KLRHD7	HD Landscape Rake 7'	650
KLRHD8	HD Landscape Rake 8'	726



Harley Power Rake

SMART CHOICE BENEFITS

- Available in 4', 5', 6', 7'
- Category 1 3-point hitch
- Required HP 4' 15-22, 5' 18-32, 6' 30-40, 7' 42-80
- Hydraulic angle 150
- Duel independently adjustable gauge wheels



Potato Plow

SMART CHOICE BENEFITS

- Model: KPP
- 9.5" working depth,
- 12" working width,
- 24.5" overall width
- 38" overall height
- 13" overall depth
- Weight 65 lbs
- Quick hitch compatible



Soil Compactors

SMART CHOICE BENEFITS

- Heavy Steel Pipe for consistent and smooth soil compaction
- 1" plug inlet for providing extra weight
- Optional wheel kit for easy handling of pull type compactor
- Widths of 4', 5', 6' and 7'



Core Plug Aerators

SMART CHOICE BENEFITS

- 12" diameter drum can be filled with extra weight (sand for winter use or water for summer use)
- Tines move slightly allowing for easier soil penetration
- Solid 1" cold rolled steel axle with pillow block bearings for long life
- Widths of 4', 5', 6' and 7' pull and 3 point, 8' 3-Point option



Disc Harrows

SMART CHOICE BENEFITS

- Quick hitch compatible
- Category I
- 2 1/2" tube frame
- Your choice of 16", 18" or 20"
- Widths of 54", 66", 84", 90" and 96"
- Sealed self aligning bearings
- **MIN HP REQUIREMENTS**
- 54" WIDE 16X16" DISK HARROW KDH16X16TUB
- 66" WIDE 16X18" DISK HARROW KDH16X18TUB
- 78" WIDE 20X18" DISK HARROW KDH20X18TUB
- 84" WIDE 20X20"X7" DISK HARROW KDH20x20TUB7
- 90" WIDE 20X20"X9" DISK HARROW KDH20x20TUB9
- 90" WIDE 24X20"X7" DISK HARROW KDH24X20TUB



Aerators

SMART CHOICE BENEFITS

- 12" diameter drum that can be filled with extra weight
- 2 3/4" spikes at 4" on centers
- 3pt hitch frame is 16" wide to accommodate concrete blocks
- Optional gauge wheel kit for pull type models
- Widths of 4', 5', 6' and 7' pull
- Widths of 4', 5', 6', 7' and 8' 3-Point

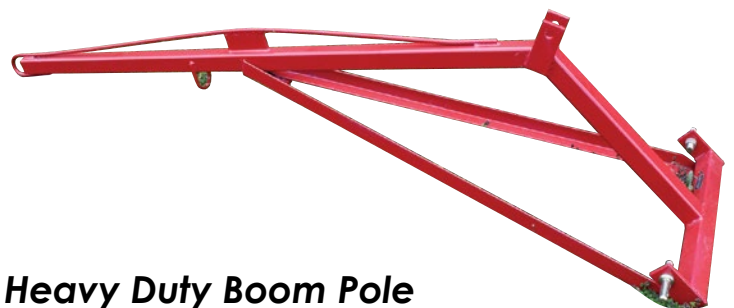

Heavy Duty Boom Pole



4-IN-1 Bucket, Skid Steer Quick Attach

SMART CHOICE BENEFITS

- Ideal for site clean up, grading, scraping, grappling, dozing and brush removal
- Single bevel bolt on dozer edge
- Double bevel bolt on clam edges, front and back

	60"	72"
Width	60.96"	72.96"
Height	27.32"	27.32"
Length	34.47"	34.47"
Clam Length	23.06"	23.06"
Backblade Length	12.36"	12.36"
Clam Opening	34.64"	34.64"
Operating Pressure (PSI)	2250	2250
Clamping Force	2354#	2354#
Weight	585#	655#
Heaped Capacity	12.23 cu/ft	17.23 cu/ft
Cylinder Specifications	Bore 2.00", Stroke 7.50", Rod Diameter 1.12"	



Rock Buckets

SMART CHOICE BENEFITS

- HD Tube Frame
- 3" Tine Spacing
- Designed to collect rocks and debris, allowing the soil to sift through



Root Grapple

SMART CHOICE BENEFITS

- Remove the toil and leave the soil
- Replaceable pin-on H&L-230 style teeth for durability and extended life
- Zinc plated, greasable pivot pins with protected grease zerks and replaceable hardened steel bushings



	60"	72"
Width	61.00"	73.00"
Height	28.14"	28.14"
Length	22.40"	22.40"
Grapple Width	57.88"	57.88"
Grapple Opening	32.50"	32.50"
Tooth Position	19.50"	19.50"
Tine Spacing	12"	12"
Weight (lbs)	382	416



5ft Grapple Bucket

SMART CHOICE BENEFITS

- Small bucket has one cylinder
- Large bucket has two cylinders
- Skid steer quick attachable
- Fits buckets 49" - 84" with 41" opening
- One 2"X8" cylinder
- 25-65HP
- 450 lbs.



6ft Grapple Bucket

SMART CHOICE BENEFITS

- Small bucket has 2 cylinder
- Large bucket has two cylinders
- Skid Steer attachable
- Fits buckets 49" - 84" with 41" opening
- One 2"X8" cylinder
- 35-85 HP
- 650 lbs.



Double Bale Spears

SMART CHOICE BENEFITS

- Skid steer quick attachable
- 3500 lb capacity at 23.25 inches

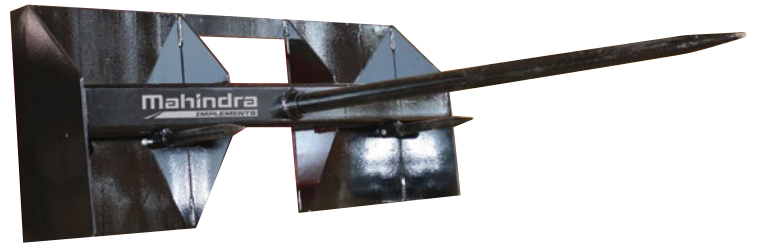

Single Bale Spears

SMART CHOICE BENEFITS

- Skid steer quick attachable
- 2500 lb capacity at 23.25 inches



Add On Grapple Bucket

SMART CHOICE BENEFITS

- Add On Grapple fits buckets 49" - 84" with 41" opening
- Add On has one 2"X8" cylinder



Post Hole Diggers

SMART CHOICE BENEFITS

- Key Selling Features:
- Cat I or Cat II Hitch
- Shear Bolt Protection
- 25" Dig Depth
- Rugged gearbox with 2" diameter output shaft
- Replaceable high carbon steel cutting edge

	STANDARD	HEAVY DUTY
Weight	BPHD: 180 lbs 6" dia.: 30 lbs 9" dia.: 41 lbs 12" dia.: 60 lbs	Digger: 210 lbs
Tractor PTO	25HP to 65HP	25HP to 65HP
Hitch	Category 1 or 2	Category 1 or 2
Gear box	Heavy duty gear box with 2" diameter output shaft.	Heavy duty gear box with 2.92" dia. output shaft
Cutting edges	Made of high carbon steel and replaceable.	Made of high carbon steel and replaceable.
Depth	Digs up to 45" deep.	Digs up to 45" deep.
Protection	Shear bolt protection system.	Shear bolt protection system.
Warranty	Residential, semi-commercial, regular commercial use: 1 year	Residential, semi-commercial, regular commercial use: 1 year

Pallet Forks

SMART CHOICE BENEFITS

- Heavy duty welded steel frame construction
- Bolted parts so they may be easily replaced or removed when needed
- Guard is flush with back rest for a more secure stability

Weight	2300 lbs (unpackaged is 343 lbs) and packaged is 383 lbs. 4000 lbs (unpackaged is 361 lbs) and packaged is 404 lbs.
Hitch	Front mount for skid steer. Universal mount.
Frame	Made of welded steel construction
Guard	Bolted on so it may be removed if required.
Forks	Bolted forks are replaceable. 1.375" x 4" wide with latch.
Rails	Notched rails for added security.
Adjustable	May be adjusted from 5" to 40" wide.
2000 lbs	42" Fork
4000 lbs	48" Fork
Warranty	Residential, semi-commercial, regular commercial use: 1 year



Ask your dealer about big savings when you add snow equipment with your New Mahindra tractor



Solid Bottom Scrap Grapple w edge 48

SMART CHOICE BENEFITS

Width	48.00"
Height	25.00"
Length	31.00"
Grapple Opening	29.00"
Operating Pressure (PSI)	1500-2500
Weight (lbs)	380
Cylinder Specifications	Bore 2", Stroke 4.5", Rod Diameter 1.25"
Construction	Heavy duty construction
Warranty	Residential, semi-commercial, regular commercial use: 1 year



JAWZ Grabbing Tool

SMART CHOICE BENEFITS

- The Mahindra Implements JAWSTM Grabbing tool is a patented hydraulic attachments for removing invasive trees and shrubs of all sizes
- Vegetation is removed completely in a single pass, including the roots without resorting to burning, cutting or herbicides used in traditional land and vegetation management
- Ideal for farmer, ranchers, urban land management, construction contractors, landscape contractors, timber/forestry and land conservation.



Hydraulic Post Hole Digger SSL mount

SMART CHOICE BENEFITS

- 6 GPM tractor flow—36 RPM
- 8 GPM tractor flow—47 RPM
- 2000 PSI—1000 lb. ft. Torque
- 24" Maximum Auger size
- Min. flow 6 GPM, Max. 15GPM



Construction Box Blade

SMART CHOICE BENEFITS

- Designed for Category II 3-Point mount
- High-profile moldboard provides increased carrying capacity with minimal drag and greater boiling action
- Double Wall moldboard with heavy-duty side plates
- Reversible cutting edge
- 39.625" Height
- 45.5" Depth
- 1.38 yds capacity
- For tractors up to 20,000 lbs.
- Fine-grades, backfills, excavates, rips and scarifies
- Hydraulically actuated scarifier increases ripping penetration
- Designed for 3 point mount
- Cutting width: 84"
- Height: 39.625"
- Depth: 45.5"
- Capacity: 1.38 yd3
- Weight (app): 1,565 lbs
- Lift Capacity: <10,000 lbs.
- Operating Weight: < 20,000 lbs



Fertilizer/Spreader

SMART CHOICE BENEFITS

- Spreads grass seed, fertilizer and small grains
- Cone shaped anti-rust plastic hopper
- Category I
- Heavy Duty Gearbox
- PTO driveline
- Tube steel mail frame
- Side Panel Height 14"



Hitch sold separately

Trailer Mover

SMART CHOICE BENEFITS

- 3 pt hitch compatible
- Moves both Regular & Goose Neck Trailers



Rear Round Bale Spear w/ Trailer Mover

SMART CHOICE BENEFITS

- Overall Depth: 37.5"
- Usable Spear Length: 40"
- Overall Height: 20.5"
- Spear Max Capacity: 2000 lbs.
- Overall Width: 25"



Grass Collector 12 Bushels

SMART CHOICE BENEFITS

- Same collector for all, simply choose the specific adapter for each tractor.
- Easy hook up, is also quick hitch compatible.
- Deflector assures all 3 bags are filled equally & evenly.
- Bags are made of high resistant material yet lightweight for easy handling and dumping.
- Not Compatible with eMax20s

Model	56"
Installation	Easy hook-up to 3 Point Hitch and compatible with quick hitch.
Dimensions	56"x 24"x 6"
Weight	350 lbs approx.
Bag Catcher	11.75 bu. capacity in three bag catchers
Spring	2 gas springs to help open the lid.
Hood	Steel hopper hood.
Deflector	Deflector makes sure all three bags are filled evenly
Belt Guard	Protective guard
Blower	Belt drive fan for easy setup
Chute	Connecting tube from blower to bag catcher
Bags	3 separate bags for easy handling and dumping
Warranty	Residential, light commercial or utility use: 2 yrs

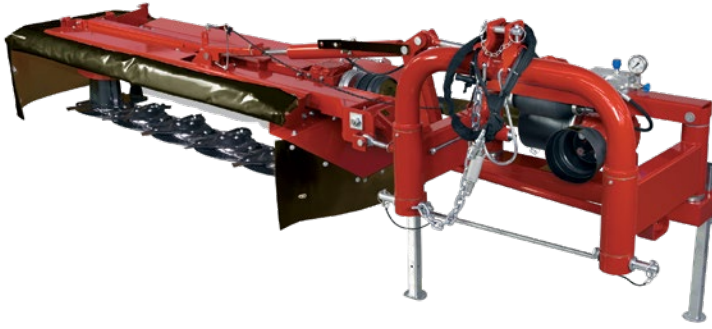

Disc Mower

SMART CHOICE BENEFITS

- Hydraulic system makes fast, precise steps, allowing easy transition from work to transport position.
- Cutter bars come with two blade discs.
- Built in safety drive gear (SDG) protects components in the event of hitting an object in the field.

MODEL	mDM7	mDM8	mDM9
Cutting Width	6' 8"	7' 9"	9' 2"
N° Discs	5	6	7
Blades Per Disc	2	2	2
Spring Pressure Regulation	Yes	Yes	Yes
PTO	540	540	540
Belt Transmission	Yes	Yes	Yes
Lock	Hydraulic	Hydraulic	Hydraulic
Weight	926 lbs.	1014 lbs.	1234 lbs.
Required HP	40	45	50

Wheel Rake

SMART CHOICE BENEFITS

- Suspension rod floating system adapts pressure to terrain without damaging the forage.
- Lightweight frame and self-correcting ground contact is ideal for small tractors.

MODEL	8 Wheel	10 Wheel
Work Width	17.7'	21'
Transport Width	8' 3"	8' 3"
N° Rotors	7 to 9	8 to 10
N° Teeth Per Rotor	40	40
Third Support Wheel	Upon Request	Not Available
Third Piston	Not Available	8-10 Upon Request
Required HP	45 HP	50 HP
Hitch	Drawbar with Shaft and Jackstand	Drawbar with Shaft and Jackstand
Weight	1367 lbs.	1543 lbs.



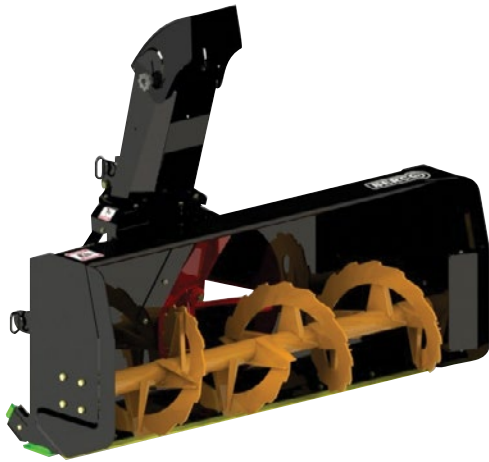

3-Point Hitch Snow Blower 56 in

SMART CHOICE BENEFITS

- Hydraulic or Electric Chute Rotation Standard - Optional Electric Deflector control
- 56" Cut 27" Tall
- Aggressive saw tooth auger will chop up snow or icy snow with ease
- High speed 4-Blade Impeller
- Double layer base behind the scraper blade to protect from damage
- Reversible/replaceable scraper bar made of Hardox 400 steel
- Warranty: 2 year residential, light commercial or utility use
- 2" Timing Belt Requires no maintenance



3-Point Hitch Snow Blower 64 in

SMART CHOICE BENEFITS

- Hydraulic or Electric Chute Rotation Standard - Optional Electric Deflector control
- 64" Cut 27" Tall
- Aggressive saw tooth auger will chop up snow or icy snow with ease
- Full Chain guard with tensioner - High speed 4-Blade Impeller
- Double layer base behind the scraper blade to protect from damage
- Reversible/replaceable scraper bar made of Hardox 400 steel
- Warranty: 2 year residential, light commercial or utility use



3-Point Hitch Snow Blower 78 in

SMART CHOICE BENEFITS

- Hydraulic or Electric Chute Rotation Standard - Optional Electric Deflector control
- 78" Cut 28" Tall
- Aggressive saw tooth auger will chop up snow or icy snow with ease
- Full Chain guard with tensioner - High speed 4-Blade Impeller
- Double layer base behind the scraper blade to protect from damage
- Reversible/replaceable scraper bar made of Hardox 400 steel
- Warranty: 2 year residential, light commercial or utility use

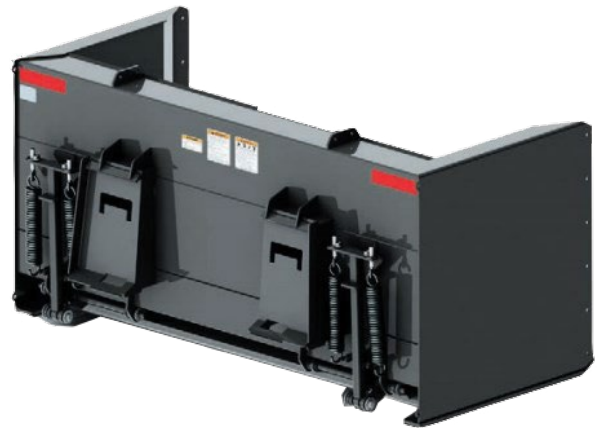

Trip Edge Snow Push 78" to 120"

SMART CHOICE BENEFITS

- Designed for loader with less than 2000lb capacity
- Maximum Tractor Weight 8000 LBS
- 30.8" High & 34" Deep
- Adjustable skid shoes
- Reversible & replaceable rubber cutting edge
- Back Drag with rubber cutting edge available
- Marker kit available
- Skid Steer Style QA for easy hookup
- 78", 96", 108", 120"



eMax, Max and Max XL Snow Blowers Front Mount

SMART CHOICE BENEFITS

- Hydraulic Chute Rotation Standard
- 56" cut and 23" tall
- Optional Electric Deflector control
- Saw Tooth Auger with Gear Box Drive (no chain) 14" 4 Blade Impeller
- Reversible/replaceable scraper bar in Hardox 400 steel -
- Double layer base behind the scraper blade to protect from damage
- Timing Belt Drive requires no maintenance, no adjustments, eliminates vibration and reduces noise
- Interchangeable using the same frame as the blade and broom
- Snow Blower uses the loader valve to lift and rotate the chute
- Warranty: 2 year residential/ light commercial use



1526-1533, 1538, 2538 & 3016, 3616 Snow Blower Front Mount

SMART CHOICE BENEFITS

- Hydraulic Chute Rotation Standard
- 66" cut and 27" tall
- Optional Electric Deflector control
- Aggressive saw tooth auger will chop up snow or icy snow with ease
- Auger powered by heavy duty gear box, (not chain)
- 18" 4 Blade Impeller
- High Performance machine using Timing Belt Drive, requires no maintenance, no adjustments, eliminates vibration and reduces noise
- Interchangeable using the same frame as the blade and broom
- Reversible/replaceable scraper bar made of Hardox 400 steel
- Double layer base behind the scraper blade to protect from damage
- Warranty: 2 year residential, light commercial or utility use



2555 HST - 78" Front Snow Blower

SMART CHOICE BENEFITS

- Hydraulic Chute Rotation and Hydraulic Deflector control standard
- 78" cut and 28" tall
- Aggressive 19" saw tooth auger will chop up snow or icy snow with ease
- Full Chain guard with tensioner - 26" 4 Blade Impeller, 3/8" thick
- High Performance machine using HD commercial grade gear box
- Reversible/replaceable scraper bar made of Hardox 400 steel 3/8"x 3"
- Double layer base behind the scraper blade to protect from damage
- 1/2" thick reinforcements at each end to avoid damage
- Warranty: 2 year residential, light commercial or utility use



Skid Steer Mt Eng. Driven Snow Blower

SMART CHOICE BENEFITS

- Electric Chute Rotation Standard - Electric Deflector control
- 54" Cut 27" Tall includes 20 HP Honda Motor
- 66" Cut 27" Tall Choice of 22 HP Honda / 25 HP Kohler
- Aggressive saw tooth auger will chop up snow or icy snow with ease
- Auger powered by heavy duty gear box, (not chain) - High speed 4-Blade Impeller
- Double layer base behind the scraper blade to protect from damage
- Reversible/replaceable scraper bar made of Hardox 400 steel
- Remote engine start and chute control, 2.5 Gal Gas tank
- Adjustable/Replaceable skid shoes
- Warranty: 1 year residential/ light commercial use

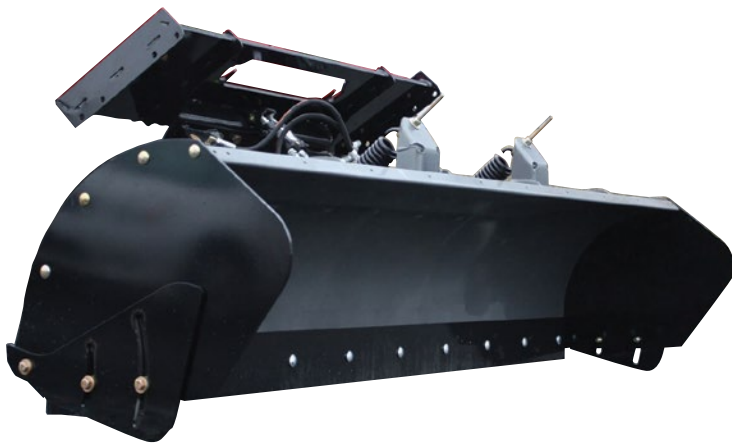

SSL Snow Blade 60" to 96"

SMART CHOICE BENEFITS

- Designed for 30-70 HP tractors
- Maximum Tractor Weight 8000 LBS
- 27" High curved blade with rear 10 gauge reinforcements
- Reversible/Replaceable Hardox cutting edge
- Adjustable Hardox skid shoes
- 0 to 30 degrees angulation, Hydraulic or manual
- Tilts 5 degrees for ground contour
- Spring loaded trip mechanism
- Skid Steer Style QA for easy hookup
- 60", 72", 84", 96"



SSL Snow Blade 84" to 144"

SMART CHOICE BENEFITS

- Designed for 70-125 HP tractors
- Maximum Tractor Weight 11,000 LBS
- 32" High curved blade with rear reinforcements, 10-gauge
- Reversible/Replaceable cutting edge -Optional rubber edge
- Adjustable Skid shoes
- 0 to 35 degrees Hydraulic Angulation
- Spring loaded trip mechanism
- Skid Steer Style QA for easy hookup
- 84", 96", 120", 144"



V-Blade Snow Plows 48" & 60"

SMART CHOICE BENEFITS

- V-Blade Snow Plows
- Five Position blade, Straight, V, Scoop, 30 Degree angle both directions
- 32.5" Blade Height
- Reversible cutting edge
- Spring loaded trip mechanism
- Blade floats 5 degrees and swivels 5 degrees for ground contour
- Skid Steer Style QA for easy hookup
- 48", 60"



Snow Push 66" to 102"

SMART CHOICE BENEFITS

- Designed for 30-70 HP tractors
- Maximum Tractor Weight 5000 LBS
- 30" High & 30" Deep
- 10ga steel with double sided walls
- Adjustable hardox skid shoes
- Reversible & replaceable rubber cutting edge
- Back Drag with rubber cutting edge available
- Marker kit available
- Choice of SSL QA or Cat 1 or 2 3-Point hook up



eMax, Max and Max XL Snow Blade

SMART CHOICE BENEFITS

- Hydraulic Angle Standard, 25 degree
- 62" x 22.5"
- Double Spring to avoid damage to blade and Tractor
- Reversible/replaceable scraper bar in hardened steel
- Snow blade uses the loader valve to lift and angle
- Interchangeable using the same frame as the blower and broom
- Parking Stand
- Warranty: 2 year residential/ light commercial use

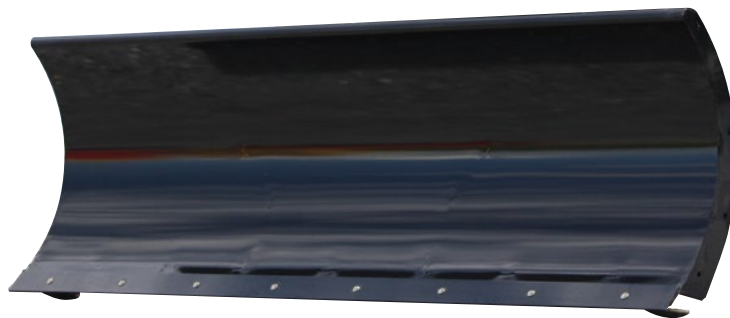

1526 - 1533, 1538, 2538 and 3016, 3616 - HD Snow Blade

SMART CHOICE BENEFITS

- Hydraulic Angle Standard, 25 degree Lifts and angles hydraulically
- 72" x 22.5"
- Double Spring to avoid damage to blade and Tractor
- Reversible/replaceable scraper bar made with hardened steel
- Interchangeable using the same frame as the blower and broom
- Parking Stand
- 2 year residential, light commercial or utility use Warranty



3pt Vibratory Plow

SMART CHOICE BENEFITS

- Hydraulic motor includes high-pressure seal and internal valve for extended motor lift and performance
- Low maintenance exciter unit generates up to 5000 lbs. of force
- Optional plow mounted cable reel and blade choices

Width (overall)	25"
Length (overall)	36"
Height (overall)	27"
Flow Requirements (GPM)	8 to 14
Operating Pressure	1,500 to 3,000
Weight (lbs)	510





eMax, Max, Max XL Rotary Broom

SMART CHOICE BENEFITS

- 60" x 18" broom
- Pivoting gauge wheels support broom weight
- Parking stand protects bristles when in storage
- Interchangeable with blade and snow blower
- Same drive kit as snow blower
- Adjustable height 1" clearance will rake lawns, leaves, pine cones etc. with less clearance you can sweep snow and debris.
- Lifts and angles hydraulically
- Warranty: 2 year residential/ light commercial use



1526 - 1533, 1538, 2538 and 3016, 3616 - Rotary Broom

SMART CHOICE BENEFITS

- 66" x 24" broom - Pivoting gauge wheels support broom weight
- Lifts and angles hydraulically
- Parking stand to protect bristles when in storage
- Interchangeable with blade and snow blower
- Same drive kit as snow blower
- Adjustable height 1" clearance will rake lawns, leaves, pine cones etc. with less clearance you can sweep snow and debris
- Warranty: 2 year residential, light commercial or utility use

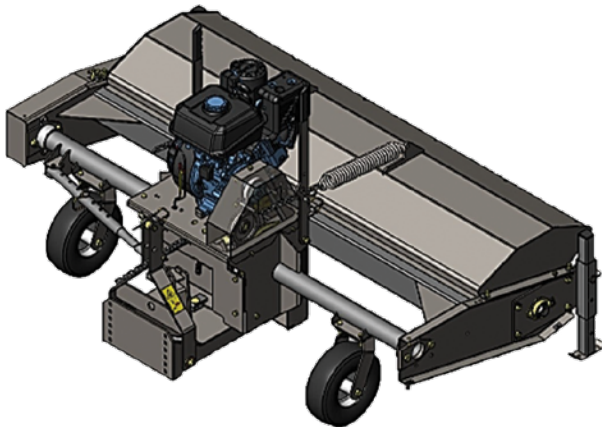

Skid Steer Mount - Engine Driven Broom

SMART CHOICE BENEFITS

- 60"x 18" broom model includes 7 HP Kohler motor
- 66"x 24" broom model includes 11 HP Honda motor
- Adjustable Brush Pressure by spring tensioner
- Full Chain guard with tensioner
- Angle Broom 20 degrees each side, manual standard, Electric optional
- Smooth electronic engagement
- Optional Side wheels for lawn detaching optional
- Warranty: 1 year residential/ light commercial use



eMax, Max, Max XL Soft Cab

SMART CHOICE BENEFITS

- Economical
- Vinyl Material
- Protects you from the elements
- Zip up doors
- Large Windows for good visibility
- Velcro dressing for access under the hood

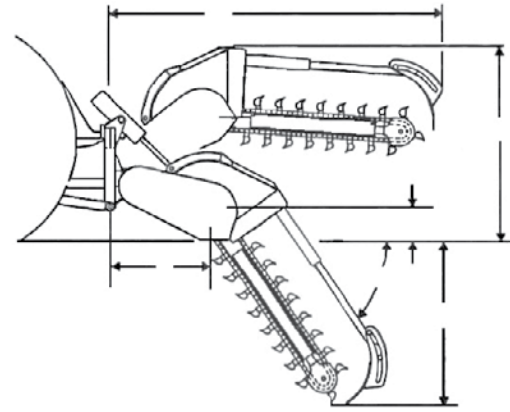

3pt Trencher - 330

SMART CHOICE BENEFITS

- Category 1ASAE S217.12 standard, 3-point mount for 15-30 PTO HP hydrostatic tractors
- Maintenance free PTO shaft drive with automatic slip clutch for overload protection
- 14" discharge auger
- 30" & 36" digging depth available to fit most applications
- 38,000 lb 1.654" anti-back flex-chain for tooth pattern versatility to support many soil types and conditions
- Compatible with model 615 chains
- ASAE S278.6 standard quick attach compatible
- Support stand is a standard feature

330 Trencher Specifications		
Transport		
Trench Depth with Auger at 65° Digging Angle	30"	36"
Chain Width	3.0"	3.0"
	4.5"	4.5"
	6.0"	6.0"
	8.0"	8.0"
Recommended Trenching Angle	65°	65°
Headshaft Height (Auger Touching Ground)	8.5"	8.5"
Overall Length	73"	79"
Overall Width	38"	38"
Overall Height	29"	29"
Spoil Discharge Reach	21"	21"
Length from 3-Point to Headshaft (center of gravity)	24"	24"
Transport Angle	48°	48°
Weight with 6" x 36" chain, boom & crumber	650 lbs	
Hydraulic System		
Operating Hydraulic System	2000 to 25000 PSI	
Rear PTO RPM Rating	540 RPM	
Rear PTO HP Rating	15 to 30 HP	

3pt Trencher - 612

SMART CHOICE BENEFITS

- PTO shaft-drive with heavy duty slip clutch for overload protection
- Gearbox drive with chain reduction to the headshaft giving productive digging chain speed
- 24" discharge auger, places dirt well away from the trench
- Several tooth options available cup, shark, rock & frost
- 50,000 lb 2" anti-back flex-chain
- 2 year limited warranty

612 Trencher Specifications	Category I
3-Point Mounting	
Trench Depth	30", 36", 48", 60"
Trench Width	6", 8", 10", 12"
Trenching Angle	65°
Auger Diameter	24"
Width	43"
Headshaft Height (auger at grade)	12"
3-point Length to Headshaft	24"
Spoil Discharge Reach	29"
Transport Height	varies
Center of Trencher to End of Auger	27"
Trencher Length with 4' boom	96"
Maximum Trenching Depths Based on Trench Width	
6" wide	60" deep
8" wide	48" deep
10" wide	36" deep
12" wide	30" deep
Digging Chain Specifications	
Double standard, anti-backflex	50,000 lbs
Standard chain pitch	2"

TRENCHER CHAIN & TEETH ASSEMBLIES

CHAIN WIDTHS

Full Shark Tooth Chain (100% shark teeth)

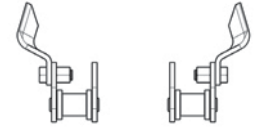
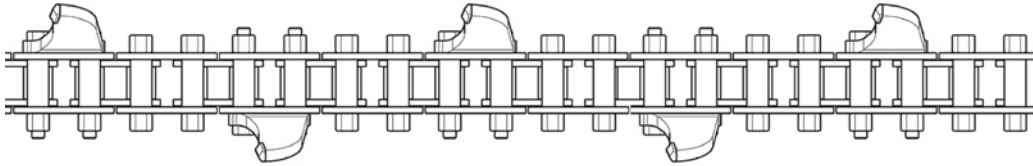

4" wide chain

70/30 Combination Chain (aggressive shark style/cup teeth) **2" Pitch**

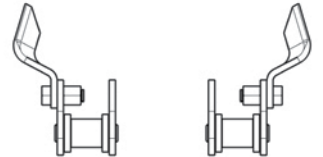
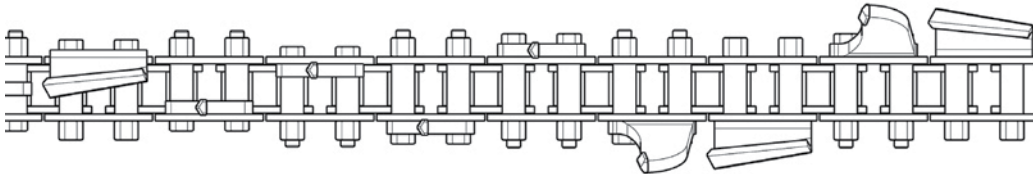

6" wide chain

50/50 Rock & Frost Chain **2" Pitch**

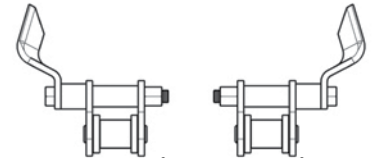
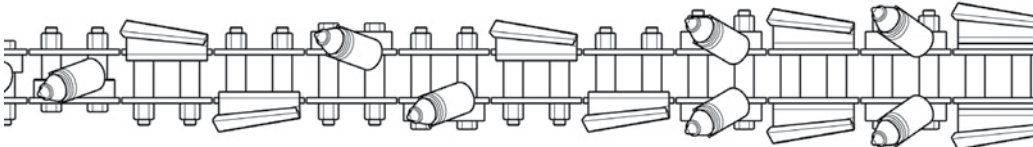

8" wide chain

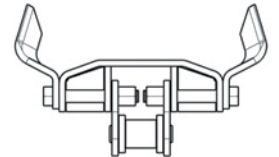

10" wide chain

Tooth Every Other Station (TEOS) 2" Pitch 50,000#

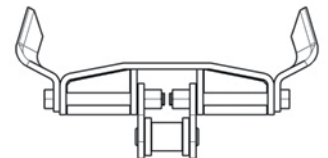
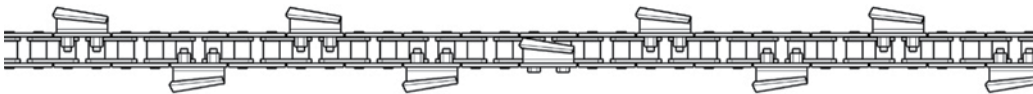

12" wide chain

Tooth Every Station (TES) 2" Pitch 50,000#

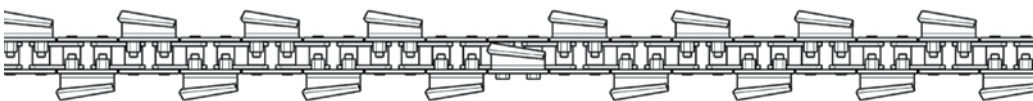

When work needs to get done you need to be able to depend on your equipment. Our material handling attachments are designed for maximum reliability, durability, and productivity.

SERIES	eMax		MAX XL	MAX XLT	1600 Series		2600 Series		3600 Series		4500 Series			5500 Series		6000 Series		7000 Series		8000 Series		9000 Series								
MODEL	eMAX 20S eMax 22L	eMax 25L	Max 25XL	Max 26XLT	1626	1533	1640	2638 - 2645	2555	2565	3640	3650	4540 2WD	4550 4WD	4550 2WD	4550 4WD	4565	5545	5555	5570	6065	6075	7085	7095	8090	8100	9110	9125		
48" (4') STANDARD DUTY CUTTER	x	x	x	x																										
60" (5') STANDARD DUTY CUTTER				x	x	x	x	x																						
72" (6') STANDARD DUTY CUTTER								x	x	x	x	x	x	x	x	x	x	x												
60" (5') MD CUTTER SHEAR PIN					x	x	x	x																						
72" (6') MD CUTTER SHEAR PIN								x	x	x	x	x	x	x	x	x	x	x	x	x	x	x	x	x	x	x	x	x	x	
72" (6') MD 2 TAIL WHEEL											x	x	x	x	x	x	x	x	x	x	x	x	x	x	x	x	x	x	x	
60" (5') MD CUTTER W/SLIP CLUTCH					x	x	x	x																						
72" (6') MD CUTTER W/SLIP CLUTCH								x	x	x	x	x	x	x	x	x	x	x	x	x	x	x	x	x	x	x	x	x	x	
72" (6') MD SLIP CLUTCH 2 TAIL WHEELS									x	x	x	x	x	x	x	x	x	x	x	x	x	x								
60" (5') HD - 1 TW - 90 HP GEAR BOX																								x	x	x	x	x	x	x
72" (6') HD - 2 TW - 90 HP GEAR BOX													x										x	x	x	x	x	x	x	x
84" (7') HD - 2 TW - 90 HP GEAR BOX												x						x	x	x	x	x								
96" (8') LIFT CUTTER												x	x					x	x	x	x	x	x	x	x	x	x	x	x	x
120" (10') HD CUTTER PULL S/C													x						x	x	x	x	x	x	x	x	x	x	x	x
15' FLEX WING CUTTER																							x	x	x	x	x	x	x	x
48" (4') FINISH MOWER	x	x	x																											
60" (5') FINISH MOWER	x	x	x	x	x	x	x	x																						
72" (6') FINISH MOWER					x	x	x	x	x	x	x	x	x	x	x	x	x													
84" (7') FINISH MOWER									x	x	x	x	x	x	x	x	x													
BOX SCRAPER 4 FT.	x	x	x	x																										
BOX SCRAPER 5 FT.	x	x	x	x	x	x	x	x																						
BOX SCRAPER 6 FT.				x	x	x	x	x	x	x																				
BOX SCRAPER 7 FT.									x	x																				
BOX SCRAPER 8 FT.																														
CONTRACTOR BOX BLADE 84"																			x	x	x	x	x	x	x	x	x	x	x	x
48" (4') ECONOMY BLADES	x	x	x	x																										
60" (5') ECONOMY BLADES	x	x	x	x							x																			
72" (6') ECONOMY BLADES				x	x	x	x	x			x		x																	
84" (7') ECONOMY BLADES					x	x	x	x					x																	
STANDARD DUTY SLIDER BLADE 4'	x	x	x	x																										
STANDARD DUTY SLIDER BLADE 5'	x	x	x	x																										
STANDARD DUTY SLIDER BLADE 6'											x	x	x	x	x	x	x	x	x	x	x	x	x	x	x	x	x	x	x	x
STANDARD DUTY SLIDER BLADE 7'												x	x	x	x	x	x	x	x	x	x	x	x	x	x	x	x	x	x	x
STANDARD DUTY GRADER BLADE 4' - TILT	x	x	x	x																										
STANDARD DUTY GRADER BLADE 5' - TILT	x	x	x	x																										
STANDARD DUTY GRADER BLADE 6' - TILT											x	x			x	x	x	x	x	x	x	x	x	x	x	x	x	x	x	x
STANDARD DUTY GRADER BLADE 7' - TILT												x			x	x	x	x	x	x	x	x	x	x	x	x	x	x	x	x
MEDIUM DUTY BLADE 5'				x	x	x	x																							
MEDIUM DUTY BLADE 6'					x	x	x	x	x	x	x	x	x	x	x	x														
MEDIUM DUTY BLADE 7'									x	x	x	x	x	x	x	x														
5' MEDIUM DUTY OFFSET BLADE	x	x	x	x	x	x	x				x																			
6' MEDIUM DUTY OFFSET BLADE				x	x	x	x	x	x	x	x	x																		
7' MEDIUM DUTY OFFSET BLADE									x	x																				
6' HEAVY DUTY BLADE											x	x			x	x														
7' HEAVY DUTY BLADE												x			x	x	x	x	x	x	x	x	x	x	x	x	x	x	x	x
8' HEAVY DUTY BLADE																	x													
LANDSCAPE RAKE STANDARD 4'	x	x																												
LANDSCAPE RAKE STANDARD 5'				x	x																									
LANDSCAPE RAKE STANDARD 6'				x	x						x																			
LANDSCAPE RAKE STANDARD 7'											x	x			x	x	x													
LANDSCAPE RAKE STANDARD 8'											x	x			x	x	x													

SERIES	eMax		MAX XL	Max XLT	1600 Series			2600 Series			3600 Series			4500 Series			5500 Series			6000 Series		7000 Series		8000 Series		9000 Series			
MODEL	eMAX 20S eMax 22L	eMax 25L	Max 25XL	Max 26XLIT	1626	1533	1640	2638 - 2645	2555	2565	3640	3650	4540 2WD	4550 4WD	4550 2WD	4550 4WD	4565	5545	5555	5570	6065	6075	7085	7095	8090	8100	9110	9125	
4' HEAVY DUTY LANDSCAPE RAKE																													
5' HEAVY DUTY LANDSCAPE RAKE																													
6' HEAVY DUTY LANDSCAPE RAKE											x		x																
7' HEAVY DUTY LANDSCAPE RAKE											x	x			x	x	x	x	x	x	x	x	x	x	x	x	x	x	
8' HEAVY DUTY LANDSCAPE RAKE												x			x	x	x	x	x	x	x	x	x	x	x	x	x	x	
60" (5') LAND LEVELER	x	x	x											x															
72" (6') LAND LEVELER					x	x	x	x	x	x	x	x	x	x	x	x		x											
84" (7') LAND LEVELER																	x		x	x	x	x	x	x	x	x	x		
16X16 DISC HARROW TUBE 54"	x	x	x	x																									
16X18 DISC HARROW TUBE 66"				x	x	x	x	x																					
20X18 DISC HARROW TUBE 66"					x	x	x	x	x	x	x	x	x	x	x	x	x	x	x										
20X20 DISC HARROW TUBE 84"									x	x	x	x	x	x	x	x	x	x	x	x	x	x	x	x	x	x	x		
24X20 DISC HARROW TUBE 96"									x	x	x	x	x	x	x	x	x	x	x	x	x	x	x	x	x	x	x		
52" COMPACT TILLER – CHAIN DRIVE	x	x	x	x																									
4' TILLER SMOOTH TOP	x	x	x	x																									
5' TILLER SMOOTH TOP				x							x				x	x													
6' TILLER SMOOTH TOP											x	x	x	x	x	x	x		x	x	x	x	x	x	x	x	x	x	
POST HOLE DIGGER LESS AUGER		x	x	x	x	x	x	x	x	x	x	x	x	x	x	x		x	x	x	x	x							
12" AUGER ONLY	x	x	x	x	x	x	x	x	x	x	x	x	x	x	x	x		x	x	x	x	x							
6" AUGER ONLY	x	x	x	x	x	x	x	x	x	x	x	x	x	x	x	x		x	x	x	x	x							
9" AUGER ONLY	x	x	x	x	x	x	x	x	x	x	x	x	x	x	x	x		x	x	x	x	x							
FERTILIZER SPREADER LIFT TYPE 1020#					x	x	x	x	x	x	x	x	x	x	x										x		x	x	
FERTILIZER SPREADER LIFT TYPE 480#	x	x	x	x	x	x	x	x	x	x	x	x	x	x	x	x		x	x	x	x	x							



We have tripled the size of our parts operation to a 120,000 square foot warehouse which currently offers more than 40,000 items. The expansion supports and fuels our growth from order placement to shipment with same or next day shipment on all orders. Behind the scenes a team of Dealer Representatives are available 8 AM to 5 PM (Central) for live parts support. In addition, the Mahindra Parts Catalog System offers 24/7 look up, order entry and return. Embedded in the catalog system is an iOS & Android mobile application plus an integrated in Dealer Website for customers and is configured with unique features. Our product range includes spare parts for Tractors, Attachments and Utility Vehicles plus numerous competitive items such as Lubricants, Fuel Additives, Chemicals, Anti-Freeze, Canopies, GloPower and Oil & Filter Service Packs.

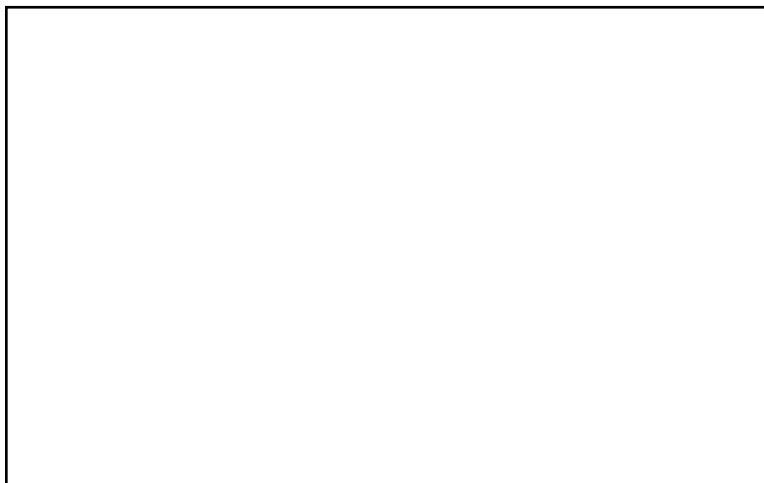

For more information go to
www.mahindrausa.com

